

Datasheet

Subject to technical alteration
Issue date: 01.11.2017

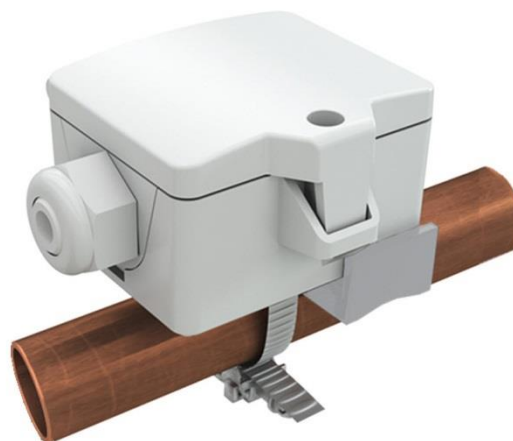

Application

Sensor with hinged lid enclosure USE for temperature measurement of pipes and round surfaces. Spring loaded brass contact sensor.

Types Available

Contact sensor temperature – passive

VFG54+ <sensor>

Contact sensors temperature – active TRV 0..10 V | TRA 4..20 mA

VFG54+ TRV MultiRange

VFG54+ TRA MultiRange

<sensor>: PT100/PT1000/NI1000/NI1000TK5000/LM235Z/NTC.../PTC... other sensors on request

MultiRange: Measuring ranges adjustable at the transducer

Security Advice – Caution



The installation and assembly of electrical equipment should only be performed by authorized personnel.

The product should only be used for the intended application. Unauthorised modifications are prohibited! The product must not be used in relation with any equipment that in case of failure may threaten, directly or indirectly, human health or life or result in danger to human beings, animals or assets. Ensure all power is disconnected before installing. Do not connect to live/operating equipment.

Please comply with

- Local laws, health & safety regulations, technical standards and regulations
- Condition of the device at the time of installation, to ensure safe installation
- This data sheet and installation manual

Notes on Disposal



As a component of a large-scale fixed installation, Thermokon products are intended to be used permanently as part of a building or a structure at a pre-defined and dedicated location, hence the Waste Electrical and Electronic Act (WEEE) is not applicable. However, most the product may contain valuable materials that should be recycled and not disposed of as domestic waste. Please note the relevant regulations for local disposal.

General remarks concerning sensors

Especially with regard to passive sensors in 2-wire conductor versions, the wire resistance of the supply wire has to be considered. If necessary the wire resistance has to be compensated by the follow-up electronics. Due to self-heating, the wire current affects the measurement accuracy, so it should not exceed 1 mA.

When using lengthy connection wires (depending on the cross section used) the measuring result might be falsified due to a voltage drop at the common GND-wire (caused by the voltage current and the line resistance). In this case, 2 GND-wires must be wired to the sensor - one for supply voltage and one for the measuring current.

Sensing devices with a transducer should always be operated in the middle of the measuring range to avoid deviations at the measuring end points. The ambient temperature of the transducer electronics should be kept constant. The transducers must be operated at a constant supply voltage ($\pm 0,2$ V). When switching the supply voltage on/off, onsite power surges must be avoided.

Build-up of Self-Heating by Electrical Dissipative Power

Temperature sensors with electronic components always have a dissipative power, which affects the temperature measurement of the ambient air. The dissipation in active temperature sensors shows a linear increase with rising operating voltage. This dissipative power has to be considered when measuring temperature. In case of a fixed operating voltage ($\pm 0,2$ V) this is normally done by adding or reducing a constant offset value. As Thermokon transducers work with a variable operating voltage, only one operating voltage can be taken into consideration, for reasons of production engineering. Transducers 0..10 V / 4..20 mA have a standard setting at an operating voltage of 24 V =. That means, that at this voltage, the expected measuring error of the output signal will be the least. For other operating voltages, the offset error will be increased by a changing power loss of the sensor electronics. If a re-calibration should become necessary later directly on the sensor, this can be done by means of a trimming potentiometer on the sensor board.

Remark: Occurring draft leads to a better carrying-off of dissipative power at the sensor. Thus temporally limited fluctuations might occur upon temperature measurement.

Mounting Advices

The device is fixed using the tightening strap. Use contact fluid for better heat transfer between sensor and measuring medium. To avoid permeation of condensate, mount the sensor on top of the tube, if possible. The installation is possible in or across the direction of the pipe.

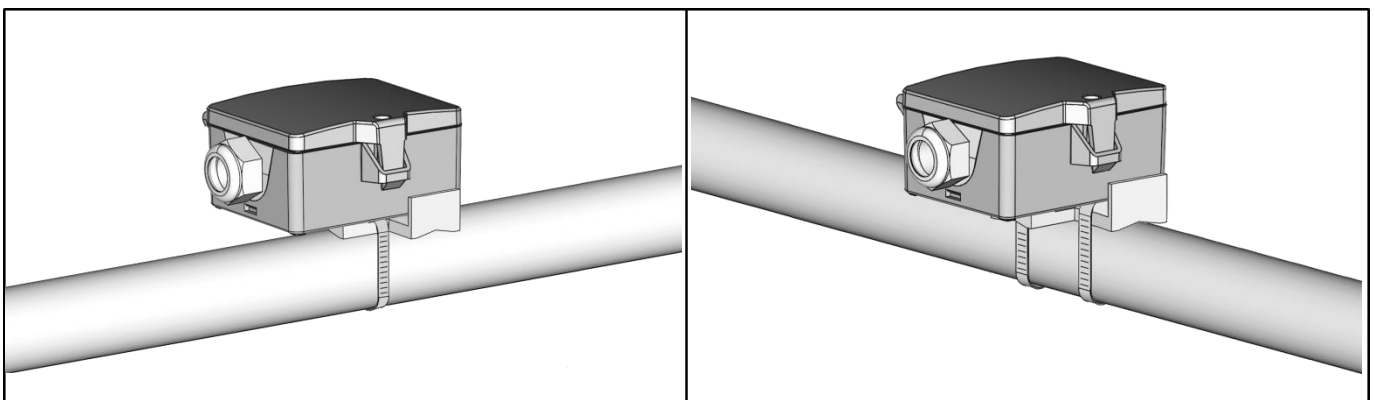

Technical Data		
Measuring values	temperature	
Output voltage	TRV 1x 0..10 V or 0..5 V, configurable via jumper, min. load 5 kΩ	
Output ampere	TRA 1x 4..20 mA, max. load 500 Ω	
Output passive	passive optional, PT100/PT1000/NI1000/NI1000TK5000/LM235Z/NTC../PTC..and other sensors on request	
Power supply	TRV 15..24 V = (±10%) or 24 V ~ (±10%) SELV	TRA 15..24 V = (±10%) SELV
Power consumption	TRV typ. 0,4 W (24 V =) 0,8 VA (24 V ~)	TRA typ. 0,5 W (24 V =)
Measuring range temp.	TRV TRA adjustable at the transducer: -50..+50 -20..+80 -15..+35 -10..+120 0..+50 0..+100 0..+160 0..+250 °C, default setting: 0..+100 °C	passive -35..+90 °C
Accuracy temperature	TRV TRA ±0,5 K (typ. at 21 °C within default measuring range)	passive typ. ±0,3 K (typ. at 21 °C), depending on used sensor
Sensor	passive optional, 2-wire (default), 3-wire or 4-wire	
Enclosure	enclosure USE-S, PC, pure white	
Protection	IP65 according to EN 60529	
Cable entry	M16 for cable max. Ø=8 mm, removeable	
Connection electrical	removeable plug-in terminal, max. 2,5 mm ²	
Pocket	brass, spring loaded sensor	
Ambient condition	TRV TRA -35..+70 °C, max. 85% rH short term condensation	passive -35..+90 °C, max. 85% rH short term condensation
Mounting	can be mounted in line or transversely to the pipe	

Connection Plan and Configuration

The adjustment of the measuring ranges is made by changing the jumpers in a de-energized state. The output value of the new measuring range is available after 2 seconds.

Passiv

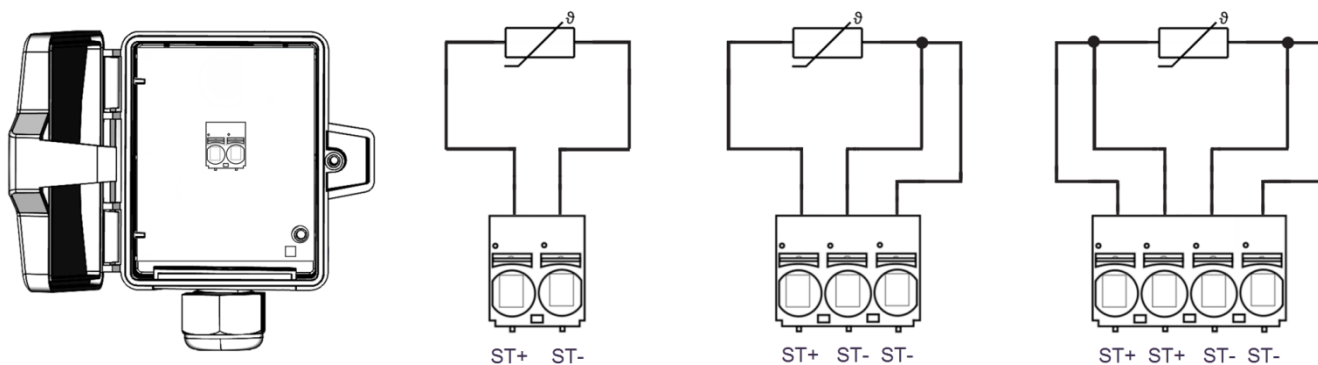
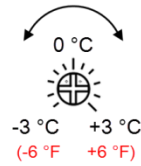
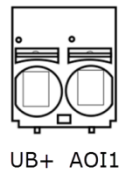
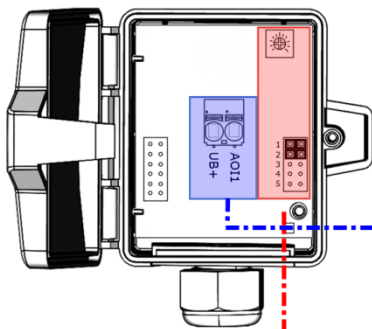

fig. (terminal assignment passive sensor)

TRA:
4..20 mA



TRV:
0..10 V | 0..5 V

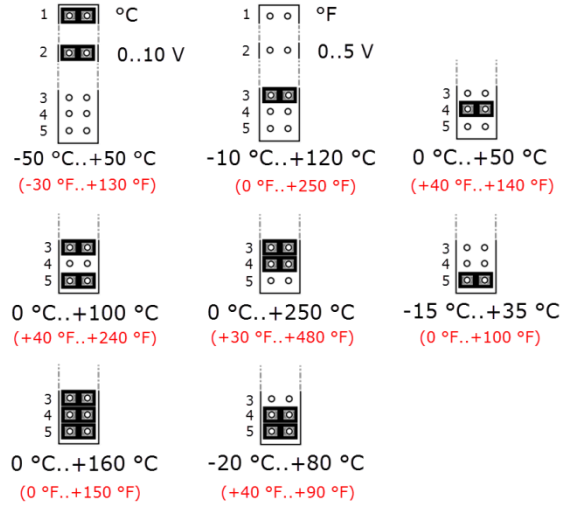
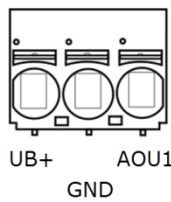
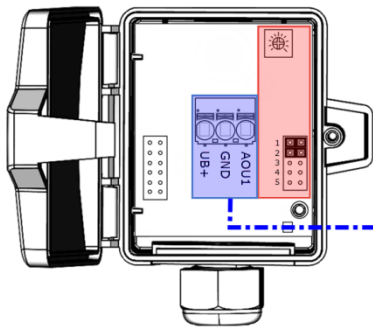
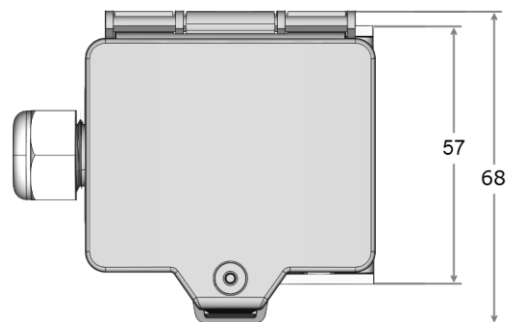
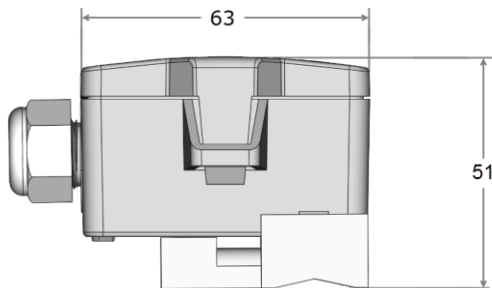

fig. (Measuring range and offset adjustment, default settings: 0 °C..+100 °C | 0 K)

Dimensions (mm)



Accessories (optional)

Tightening strap 2" with contact fluid
Tightening strap 900 mm with contact fluid

Item No. 102254
Item No. 102315

Sealing inserts cable entry (packaging unit 10 pcs.)

for wire with Ø	3 mm	5 mm	7 mm	8 mm
Item No.	641036	641012	639248	641340